

# Control of Series Active Power Filters Compensating for Source Voltage Unbalance and Current Harmonics

G.-Myoung Lee, Dong-Choon Lee, *Member, IEEE*, and Jul-Ki Seok, *Member, IEEE*

**Abstract**—In this paper, a novel control scheme compensating for source voltage unbalance and current harmonics in series-type active power filter systems combined with shunt passive filters is proposed, which focuses on reducing the delay time effect required to generate the reference voltage. Using digital all-pass filters, the positive voltage sequence component out of the unbalanced source voltage is derived. The all-pass filter can give a desired phase shift and no magnitude reduction, unlike conventional low- or high-pass filters. Based on this positive-sequence component, the source phase angle and the reference voltage for compensation are derived. This method is easier to implement and to tune controller gains. In order to reduce the delay time effect in the voltage control loop, the reference voltage is predicted a sampling period ahead. The validity of the proposed control scheme has been verified by experimental results.

**Index Terms**—All-pass filter, current harmonics, reference prediction, series active filter, voltage unbalance.

## I. INTRODUCTION

IN RECENT years, there has been a considerable interest in the concern of power quality and voltage stability of utility at nonlinear load. The unbalanced source voltage may generate low-order harmonic current components in the power system and also cause a negative sequence current and torque reduction in case of electric machine drive systems. In addition, harmonic contamination of the power system by nonlinear loads such as rectifiers, inverters and cyclo-converters is an inevitable problem, since adjustable speed drives become common in industrial applications [1].

In the past, power quality problems are mainly focused on the harmonic contamination. The problems can be solved by the help of shunt active power filters, which are regarded as a kind of current source compensating for the harmonic current due to nonlinear loads [2], [3]. However, the cost of shunt active filters is relatively high and they are not preferable for a large-scale system since the power capacity of the filter should be directly proportional to the load current to be compensated. In addition, their compensating performance is better in the current-type harmonic source than in the voltage-type harmonic source [4], [5].

Manuscript received April 16, 2002; revised April 2, 2003. Abstract published on the Internet November 26, 2003. This work was supported by the Korea Research Foundation under Grant KRF-2000-0041-E00158. This paper was presented at the 27th Annual Conference of the IEEE Industrial Electronics Society, Denver, CO, November 29–December 2, 2001.

G.-Myoung Lee was with the School of Electrical Engineering and Computer Science, Yeungnam University, Kyongbuk 712-749, Korea. He is now with Advanced Drive Technology Company, Ltd., Kyungki-Do, Korea.

D.-C. Lee and J.-K. Seok are with the School of Electrical Engineering and Computer Science, Yeungnam University, Kyongbuk 712-749, Korea (e-mail: dclee@yu.ac.kr).

Digital Object Identifier 10.1109/TIE.2003.822040

To solve these difficulties, the series active filter was introduced at the end of the 1980s [5], [6]. The series active filter works as a kind of harmonic isolator rather than a harmonic voltage generator, since it provides a high impedance for the harmonics while providing a zero impedance for the fundamental. Also, the series active power filter can regulate the point of common coupling (POCC) voltage at a desired value by controlling the inverter output so as to compensate for abnormal utility voltage [7], [8]. Even though the series-type active filter is most preferable for protecting consumers from an inadequate power quality, there is a generic difficulty in implementation due to the time-delay effect in controlling the active filter system, since additional low- or high-pass filters are usually used in generating the reference voltage for unbalance utility and harmonic current compensation [8]–[11]. In the extreme case, the delay time of the digital filter may cause stability problems [12]. Therefore, the reference generation method eliminating the time delay is necessary to control the active power filter systems. For this purpose, artificial neural networks and deadbeat control have been applied to the compensation schemes to reduce the delay time. However, a neural network requires a learning process in advance [13] and deadbeat control is subject to system parameter perturbation [14].

In this paper, a novel control scheme compensating the source voltage unbalance and the harmonic current for the combined system of the series active and shunt passive power filter system is proposed. For a compensation of abnormal utility voltage, the desired fundamental component of the source voltage is derived from the positive-sequence component of the unbalance voltage. Here, instead of low- or high-pass filters, a digital all-pass filter giving a desired phase shift and no magnitude reduction is employed. Also, the derived fundamental component is used for the harmonic current compensation, where it is regarded as the fundamental voltage component applied to the load. Therefore, using the high-pass filter, which may incur control instability, can be avoided. In order to reduce the delay-time effect in the voltage control loop, the reference voltage is predicted a sampling period ahead. The validity of the proposed scheme has been verified for the small prototype hybrid active power filter system.

## II. HYBRID SYSTEM OF SERIES ACTIVE AND SHUNT PASSIVE FILTERS

Fig. 1 shows the power circuit of a series active filter system with shunt passive filters. The  $LC$  passive filters tuned at the 5th and 7th harmonic frequency are paralleled, which work as a harmonic sink path and lower the power rating of active filters. A three-phase inverter is connected in series with the power line

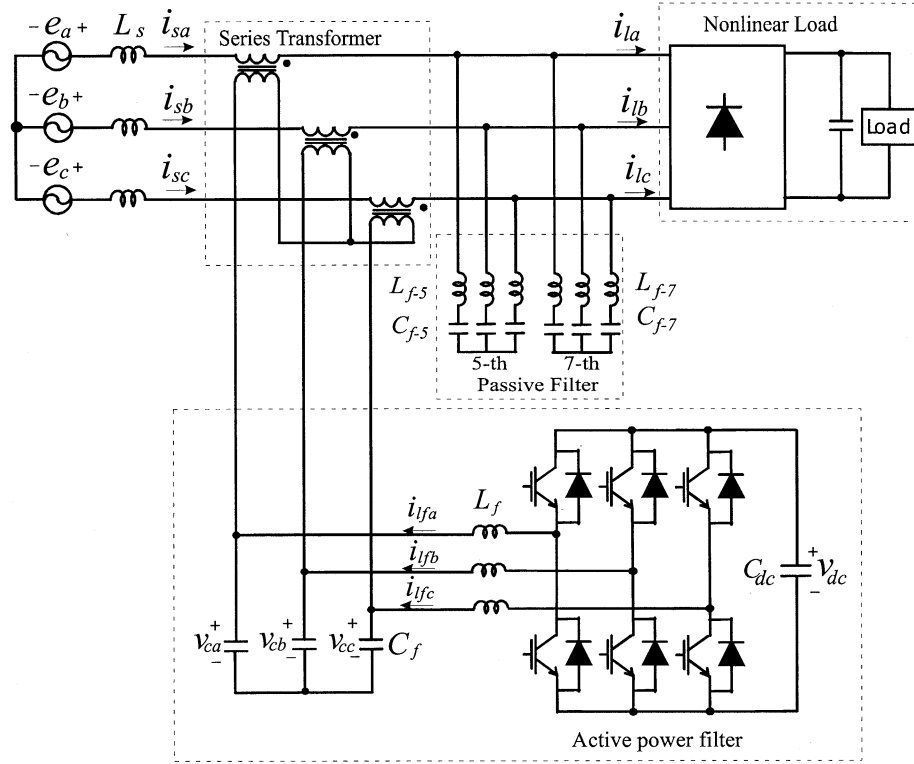

Fig. 1. Series active power filter with shunt passive filter.

to inject the compensation voltage. The turn ratio of the series transformer connecting the active power filter to the power line is chosen to be unity for convenience. The load is a three-phase diode rectifier having both characteristics of voltage-type and current-type harmonic sources.

#### A. Positive-Sequence Component and Source Phase Angle

For unbalanced source voltages, the phase angle of the reference frame is normally chosen as that of the positive-sequence component derived from an unbalanced voltage set, which is expressed as

$$\begin{bmatrix} e_{a(+)} \\ e_{b(+)} \\ e_{c(+)} \end{bmatrix} = \begin{bmatrix} \frac{1}{3} \left\{ e_a - \frac{e_b}{2} - \frac{e_c}{2} \right\} - \frac{1}{j2\sqrt{3}}(e_b - e_c) \\ \frac{1}{3} \left\{ e_b - \frac{e_c}{2} - \frac{e_a}{2} \right\} - \frac{1}{j2\sqrt{3}}(e_c - e_a) \\ \frac{1}{3} \left\{ e_c - \frac{e_a}{2} - \frac{e_b}{2} \right\} - \frac{1}{j2\sqrt{3}}(e_a - e_b) \end{bmatrix} \quad (1)$$

where  $e_a, e_b, e_c$  and  $e_{a(+)}, e_{b(+)}, e_{c(+)}$  are instantaneous source voltages and positive-sequence components, respectively. The  $j$  in (1) means the phase shift of  $90^\circ$ , which is simply obtained by using digital all-pass filters [15] as

$$Y(s) = \frac{s^2 - bs + c}{s^2 + bs + c} X(s) \quad (2)$$

where  $b = 377 \text{ rad/s}$  and  $c = \pi/2$ . Since the all-pass filter can give a desired phase shift of  $\pi/2$  between the input and the output, with the magnitude kept unchanged, it gives better performance than the other methods using low-pass or bandpass filters in deriving the positive-sequence voltage component.

From the positive-sequence component of  $e_{a(+)}, e_{b(+)},$  and  $e_{c(+)}$  which is a balanced voltage set, the source phase angle is derived, using the  $d$ - $q$  transformation, as (3)

$$\theta_e = \tan^{-1} \frac{-e_{ds(+)} }{e_{qs(+)} } \quad (3)$$

where

$$\begin{aligned} e_{qs(+)} &= \frac{(2e_{a(+)} - e_{b(+)} - e_{c(+)})}{3} \\ e_{ds(+)} &= \frac{(e_{c(+)} - e_{b(+)})}{\sqrt{3}}. \end{aligned} \quad (4)$$

#### B. Compensation of Source Voltage Unbalance

Using (3), (4) can be transformed into a synchronous reference frame as

$$\begin{bmatrix} e_{q(+)}^e \\ e_{d(+)}^e \end{bmatrix} = \begin{bmatrix} \cos \theta_e & \sin \theta_e \\ -\sin \theta_e & \cos \theta_e \end{bmatrix} \begin{bmatrix} e_{qs(+)} \\ e_{ds(+)} \end{bmatrix} \quad (5)$$

where the superscript “ $e$ ” means a quantity in a synchronous reference frame. Thus, the required fundamental component set of the balanced source phase voltage can be calculated as

$$\begin{bmatrix} e_{a,bal} \\ e_{b,bal} \\ e_{c,bal} \end{bmatrix} = K_u \begin{bmatrix} e_{a(+)} \\ e_{b(+)} \\ e_{c(+)} \end{bmatrix} \quad (6)$$

where  $K_u$  is a gain to recover the required fundamental magnitude of  $E$ , which is expressed as

$$K_u = \frac{E}{e_{q(+)}^e}. \quad (7)$$

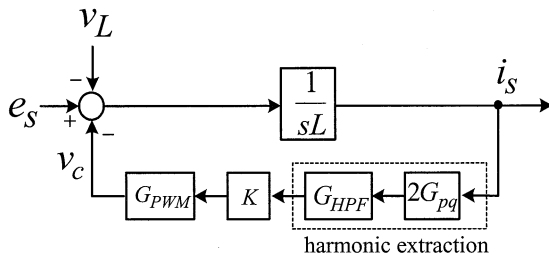

Fig. 2. Conventional control block diagram for harmonic compensation.

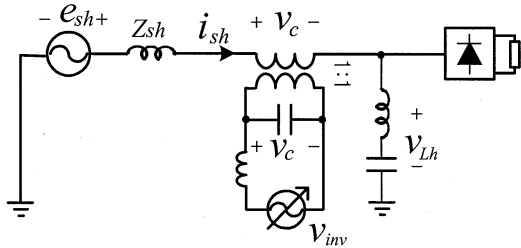

Fig. 3. Harmonic equivalent circuit.

Using (6), the reference voltage for unbalance compensation is calculated as

$$\begin{bmatrix} v_{va}^* \\ v_{vb}^* \\ v_{vc}^* \end{bmatrix} = \begin{bmatrix} e_{a,bal} - e_a \\ e_{b,bal} - e_b \\ e_{c,bal} - e_c \end{bmatrix}. \quad (8)$$

### C. Compensation of Current Harmonics

Fig. 2 shows a conventional control block diagram of the series active power filter system for the harmonic current compensation using a high-pass filter [12]. In this figure,  $e_s$  and  $v_L$  are the source and load voltages, respectively, and  $v_c$  is the injected voltage. Using the high-pass filter in the control loop may deteriorate the performance due to a time delay and degrade the stability of the active filter system. Another reference-generating method using a low-pass filter instead of the high-pass filter was studied by Akagi *et al.* [12]. However, there is also the phase and magnitude error in the fundamental component of the reference voltage due to the delay effect of low-pass filtering.

In this paper, two compensation schemes in accordance with the type of the harmonic source are proposed, where the low- or high-pass filters are not employed for the reference generation.

First, the reference voltage compensating for harmonic currents due to the voltage-type harmonic source is derived. From Fig. 3, the harmonic current of the source side is expressed as

$$i_{sh} = \frac{e_{sh} - v_c - v_{Lh}}{z_{sh}} \quad (9)$$

where  $v_{Lh}$  and  $e_{sh}$  are harmonic components of the load and source voltages, respectively, and  $z_{sh}$  is the source-side harmonic impedance. If the reference voltage for harmonic current compensation is chosen as

$$v_c^* = -v_{Lh} \quad (10)$$

the harmonic current component of the source side is suppressed to be zero provided that the source voltage is assumed to be

sinusoidal. Since  $z_{sh}$  is usually so small as to be negligible and  $v_c$  has no fundamental component,  $v_{Lh}$  can be obtained as

$$v_{Lh} = e_{bal} - v_L. \quad (11)$$

Here, to avoid using additional voltage sensors, the load voltage  $v_L$  can be estimated as

$$\hat{v}_L = e_s - v_c - i_s z_s \quad (12)$$

where the source impedance  $z_s$  is assumed to be negligible which is usually 2%–5% p.u. [5].

Second, the reference voltage compensating for the current-type harmonic source is derived from the harmonic current components of the source side as

$$v_h^* = K_{vh}(i_{s1} - i_s) \quad (13)$$

where  $i_{s1}$  is the fundamental component of the source phase current, which is calculated as

$$\begin{bmatrix} i_{sa1} \\ i_{sb1} \\ i_{sc1} \end{bmatrix} = \begin{bmatrix} 1 & 0 \\ -\frac{1}{2} & -\frac{\sqrt{3}}{2} \\ -\frac{1}{2} & \frac{\sqrt{3}}{2} \end{bmatrix} \begin{bmatrix} \cos \theta_e & \sin \theta_e \\ -\sin \theta_e & \cos \theta_e \end{bmatrix} \begin{bmatrix} I_{sq,mean} \\ I_{sd,mean} \end{bmatrix} \quad (14)$$

where  $I_{sq,mean}$  and  $I_{sd,mean}$  are mean values of the source currents transformed in a synchronous reference frame, which is obtained as

$$\begin{bmatrix} i_{sq}^e \\ i_{sd}^e \end{bmatrix} = \frac{2}{3} \begin{bmatrix} \cos \theta_e & \cos(\theta_e - \frac{2\pi}{3}) & \cos(\theta_e + \frac{2\pi}{3}) \\ \sin \theta_e & \sin(\theta_e - \frac{2\pi}{3}) & \sin(\theta_e + \frac{2\pi}{3}) \end{bmatrix} \begin{bmatrix} i_{sa} \\ i_{sb} \\ i_{sc} \end{bmatrix}. \quad (15)$$

In practice, a moving average of them for five sampling periods is sufficient.

Therefore, the reference voltages for the harmonic current compensation combining (11) and (13) are given by

$$v_h^* = K_{vh}(i_{s1} - i_s) + v_{Lh}. \quad (16)$$

where  $K_{vh}$  is a controller gain which is chosen as  $K_{vh} \gg Z_f$ , where  $Z_f$  is the equivalent impedance of the shunt passive filter [5].

### D. Control of Pulsewidth-Modulation (PWM) Inverter

From (8) and (16), the resultant reference voltage is expressed as

$$v_c^* = v_h^* + v_v^*. \quad (17)$$

Fig. 4 shows the block diagram of reference generation schemes corresponding to (17). In the inverter control block, the output voltage and current are controlled in a synchronous reference frame [17].

## III. PREDICTION OF REFERENCE VOLTAGES

Since the active power filter should compensate for the harmonics instantaneously, deriving the reference voltage in time is important for the compensation performance. To eliminate the calculation time delay of digital processors, the reference voltage in (17) needs to be predicted a sampling period ahead, where two parts are considered separately.

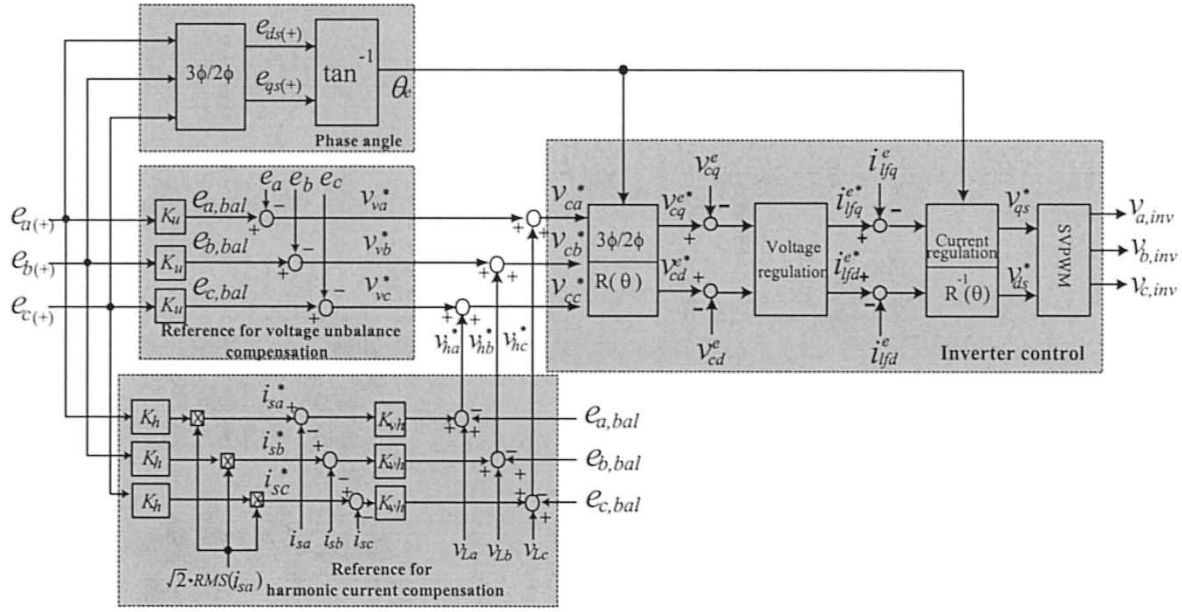

Fig. 4. Block diagram for reference generation and inverter control.

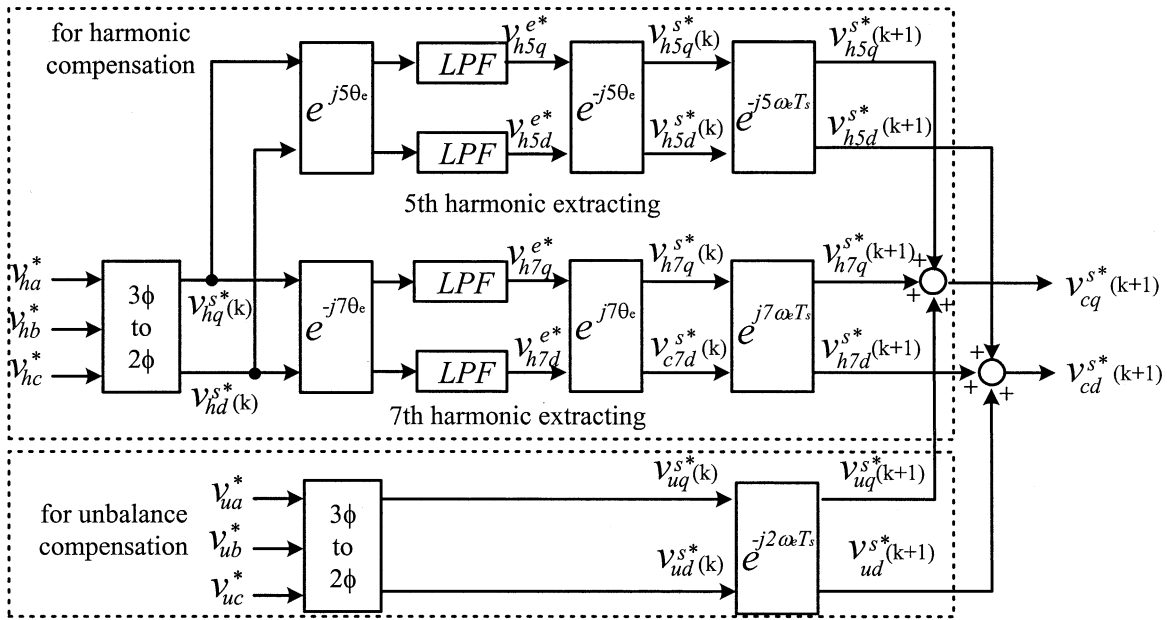

Fig. 5. Block diagram for reference prediction.

The first part is a prediction of the reference voltage of (16), where only the 5th and 7th harmonic components are considered since they are dominant harmonics. Fig. 5 shows the block diagram for extracting only the 5th and 7th harmonic components from (16) and for predicting the values one sampling period ahead. Transforming (16) into the synchronous reference frames of the 5th and 7th harmonic frequency [16], [17],

$$\begin{aligned} v_{h5}^{e*} &= e^{j5\theta_e} \cdot v_h^{s*} \\ v_{h7}^{e*} &= e^{-j7\theta_e} \cdot v_h^{s*}. \end{aligned} \quad (18)$$

By applying low-pass filtering to (18), the dc values of the 5th and 7th components of  $V_{h5}$  and  $V_{h7}$ , respectively, are obtained.

Transforming these dc components inversely in the stationary reference frames yields

$$\begin{aligned} v_{h5}^{s*}(k) &= e^{-j5\theta_e} \cdot V_{h5} \\ v_{h7}^{s*}(k) &= e^{j7\theta_e} \cdot V_{h7}. \end{aligned} \quad (19)$$

In order to derive the  $(k+1)^{\text{th}}$  reference, the 5th and 7th harmonic voltage phasors in (19) are rotated clockwise by the angle of  $5\omega_e T_s$  and counterclockwise by the angle of  $7\omega_e T_s$ , respectively, as shown in Fig. 6, which are expressed as

$$\begin{aligned} v_h^{s*}(k+1) &= v_{h5}^{s*}(k+1) + v_{h7}^{s*}(k+1) \\ &= e^{-j5\omega_e T_s} \cdot v_{h5}^{s*}(k) + e^{j7\omega_e T_s} \cdot v_{h7}^{s*}(k). \end{aligned} \quad (20)$$

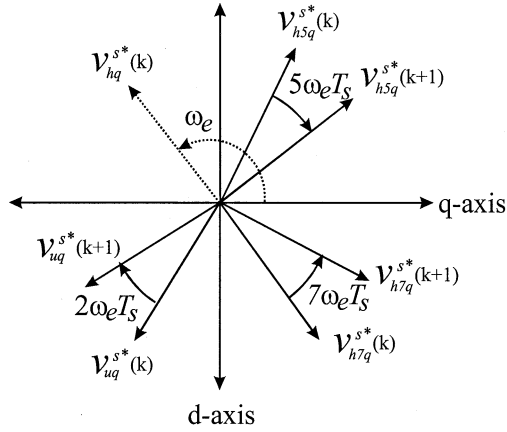

Fig. 6. Harmonic voltage phasor diagram.

TABLE I  
SYSTEM PARAMETERS

Input voltage	100[V_peak]
5 <sup>th</sup> passive filter	L=1.4[mH], C=200[uF]
7 <sup>th</sup> passive filter	L=1.4[mH], C=100[uF]
DC link capacitor	C=2350[uF]
Inverter output filter	L=1.4[mH], C=10[uF]
Switching frequency	3.5[kHz]
Series transformer	1[kVA], 110/110[V]

A prediction of the reference for the 11th and 13th components may be added to (20). In practice, however, it does not make any significant difference.

The second part of prediction is for the negative-sequence voltage component of (8). The  $(k+1)^{\text{th}}$  reference is predicted by advancing the reference voltage by the angle of  $2\omega_e T_s$  since the negative-sequence component is seen as a second-order harmonic in a synchronous reference frame based on the positive-sequence component. Thus,

$$v_v^{s*}(k+1) = e^{-j2\omega_e T_s} \cdot v_v^{s*}(k). \quad (21)$$

Combining (20) and (21), we can obtain the resultant predicted reference voltage to be injected by the series transformer as

$$v_c^{s*}(k+1) = v_{h5}^{s*}(k+1) + v_{h7}^{s*}(k+1) + v_v^{s*}(k+1). \quad (22)$$

#### IV. EXPERIMENTAL RESULTS AND DISCUSSIONS

The experiments have been performed for a 3-kVA hybrid active filter system using a digital signal processor (DSP) TMS320C31 controller. The system parameters for the experiments are listed in Table I, and the resistive load of  $30 \Omega$  is connected to the diode rectifier. The unbalanced phase voltages of the source are given as

$$\begin{aligned} e_a &= 110 \sin \omega t \\ e_b &= 90 \sin(\omega t - 130^\circ) \\ e_c &= 90 \sin(\omega t + 130^\circ) \end{aligned} \quad (23)$$

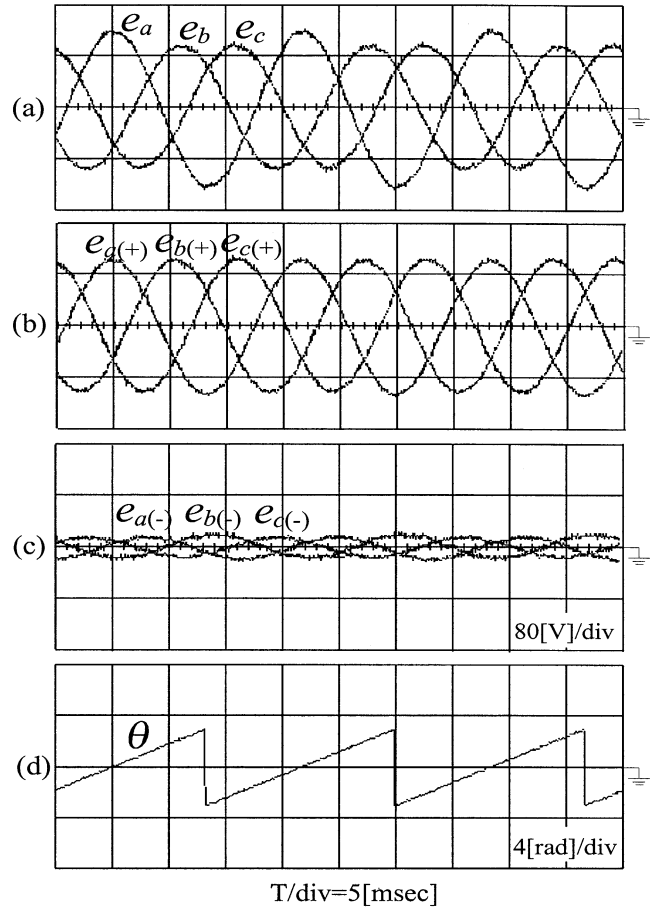

Fig. 7. Source voltage and phase angle. (a) Source voltage. (b) Positive-sequence component. (c) Negative-sequence component. (d) Phase angle.

where each phase voltage can be generated independently by the three-phase ac programmable power supply.

Fig. 7 shows the unbalanced source voltage, its positive- and negative-sequence components, and source phase angle referred to the positive-sequence component. Even though the source voltage is unbalanced, it is shown that a balanced set of the positive sequence component is obtained as in Fig. 7(b), from which the source phase angle is shown in Fig. 7(d).

As explained in Section III, extracting the 5th and 7th harmonic components from (16) is very important to predict the references one sampling period ahead. Fig. 8 shows the reference voltage for harmonic current compensation, which is given by (20). It is seen in harmonic spectrum that the only 5th and 7th harmonic components are included.

Fig. 9 shows the control performance of the inverter output voltage in the stationary reference frame. Using the predicted reference of (22) gives a better voltage control characteristic than that of (17) without prediction. Fig. 10 shows the inverter output voltage in the synchronous reference frame, where the negative-sequence component is seen at 120 Hz. The proposed method with the prediction of (22) gives a better performance than that of (17) without prediction.

Fig. 11 shows the load- and source-side current waveforms, in the case where the source voltage is balanced. Here, Fig. 11(a) is the distorted load current due to the rectifier load, Fig. 11(b) is the source current in the case of compensation with passive

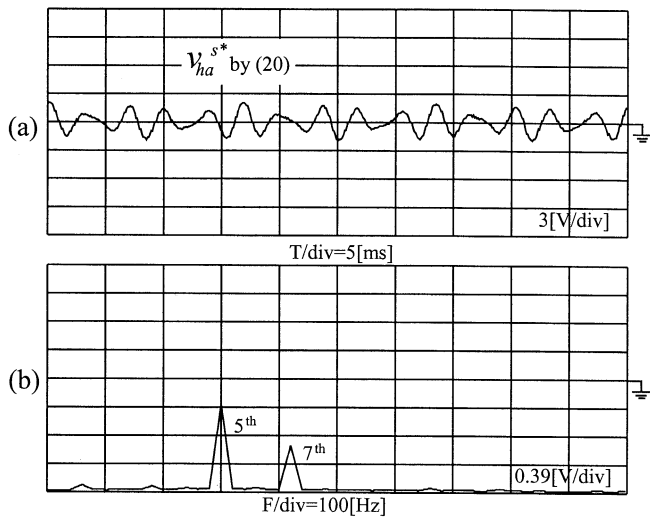

Fig. 8. Reference voltage for harmonic current compensation. (a) Reference voltage. (b) Harmonic spectrum.

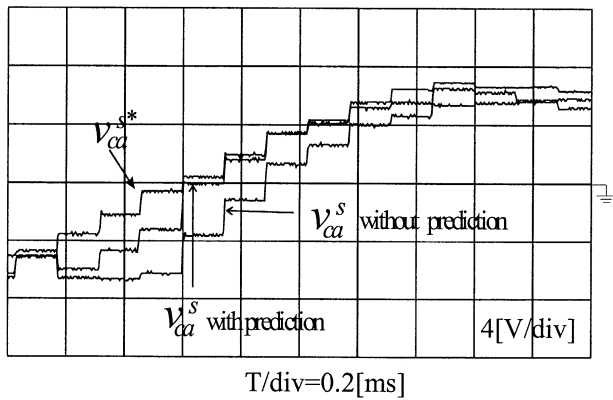

Fig. 9. Control performance of inverter output voltage.

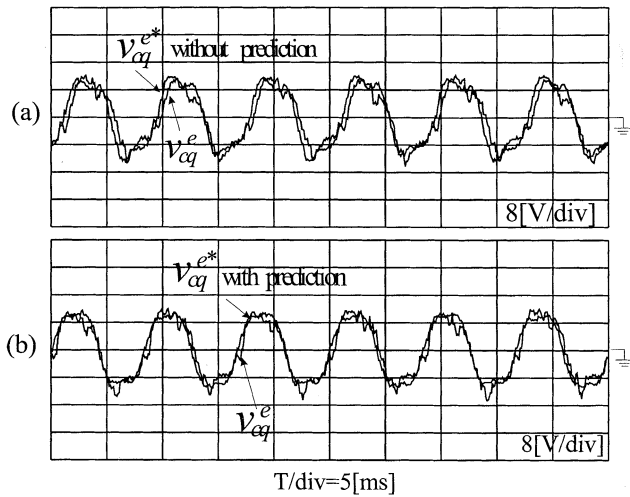

Fig. 10. Inverter output voltage. (a) Without prediction. (b) With prediction.

filters only, and Fig. 11(c) is that of active plus passive filters. The source current is close to a sinusoidal waveform with passive or active filters. Fig. 12 shows the harmonic spectrum corresponding to current waveforms illustrated in Fig. 11. The load current gives a total harmonic distortion (THD) of 44% and on

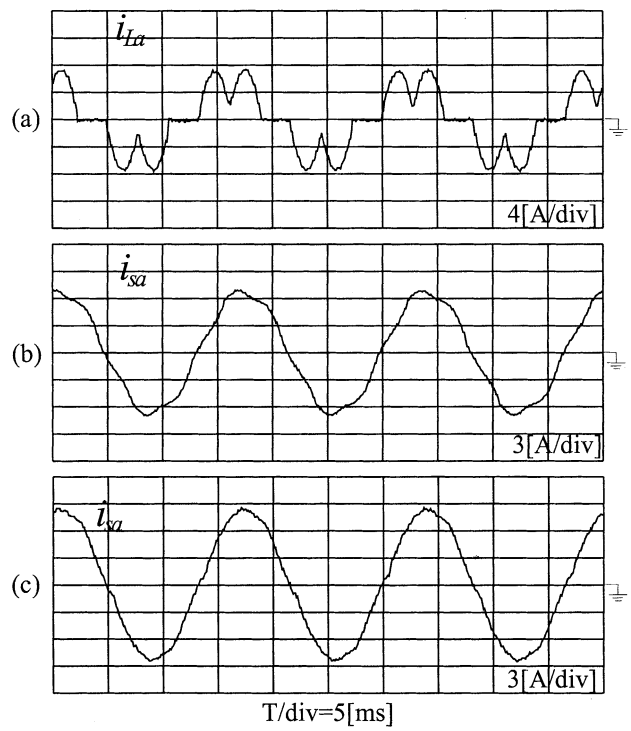

Fig. 11. Current waveforms (in case of balanced source voltage). (a) Load current. (b) Source current with passive filter only. (c) Source current with passive plus active filters.

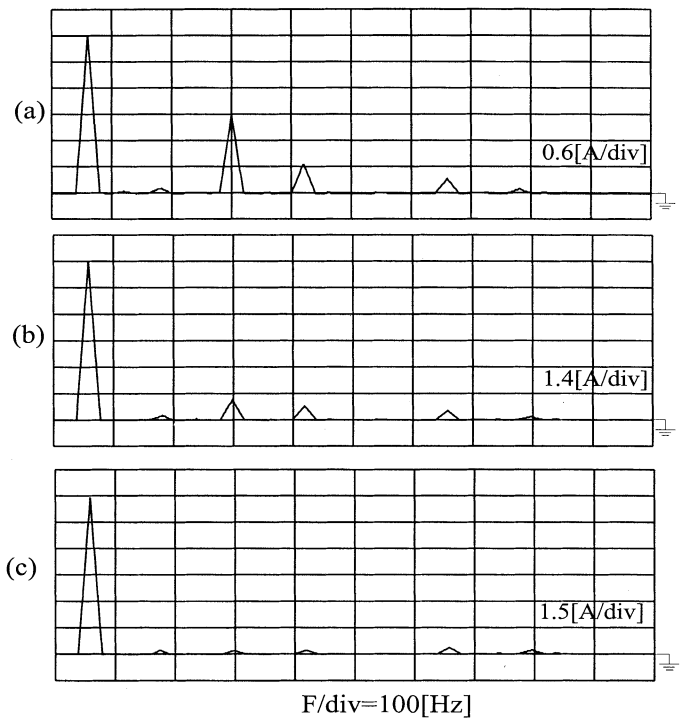

Fig. 12. Harmonic spectrum of source current. (a) Load current. (b) Source current with passive filter only. (c) Source current with passive plus active filters.

the contrary that of the source currents of Fig. 12(b) and (c) are 8% and 3.8%, respectively. It means that the power rating of active filters can be much reduced by combining the passive filter, which compensates for a great part of the harmonics, as explained in [5], [7], and [8].

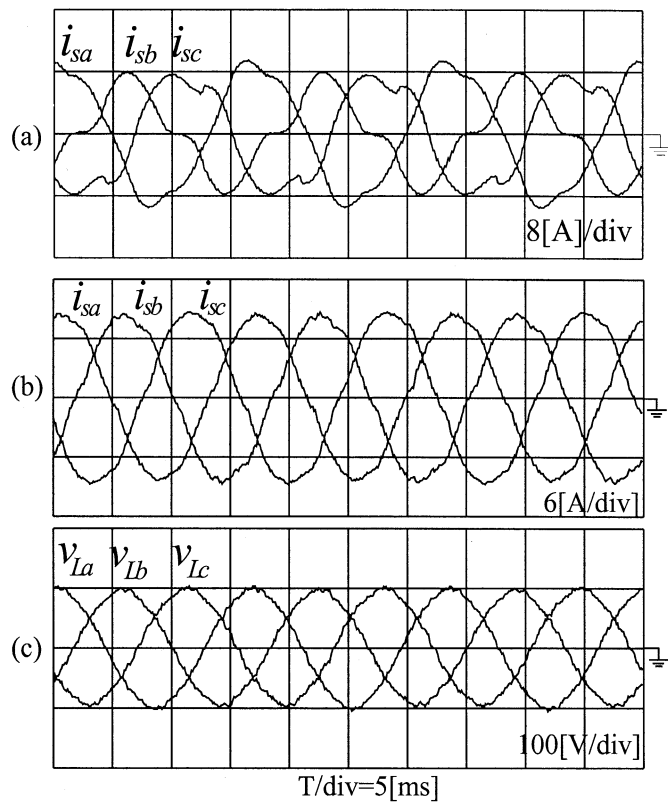

Fig. 13. Waveforms with compensation (in case of unbalanced source voltage). (a) Source current with passive filter only. (b) Source current with passive plus active filters. (c) Load voltage in case of (b).

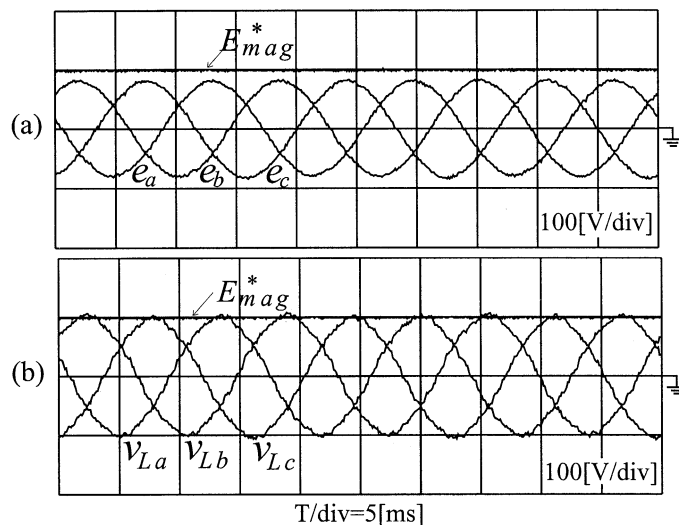

Fig. 14. Compensation of three-phase voltage sag. (a) Source voltage. (b) Load voltage.

Fig. 13 shows the source current and load voltage under unbalanced source voltage. Fig. 13(a) shows the source current with passive filters only, without the active filter. Due to the source voltage unbalance, the source currents cannot be compensated satisfactorily by the passive filter only. Moreover, in the case of the capacitive dc link of diode rectifier, the negative-sequence component of the source current is further amplified due to that of the source voltage [18]. Fig. 13(b) and

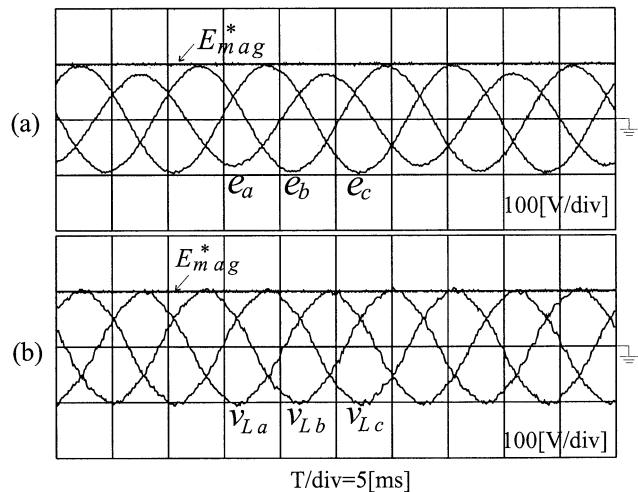

Fig. 15. Compensation of single-phase voltage sag. (a) Source voltage. (b) Load voltage.

(c) shows the source current and load voltage with the simultaneous compensation of source voltage unbalance and current harmonics by the passive plus active filter. The source current becomes sinusoidal and the load voltage is also recovered to the balanced set with the desired magnitude.

Fig. 14 shows the voltage compensation performance of the series active power filter in the case of the source voltage sag of 20% in all three phases. In spite of the source voltage sag, the load voltage is recovered to the desired magnitude. For the same amount of voltage sag in a single phase, it is shown in Fig. 15 that the load voltage is also recovered to the balanced set.

## V. CONCLUSION

In this paper, the positive voltage sequence component out of the unbalanced source voltage has been derived by using digital all-pass filters. The all-pass filter can give adjustable phase shift with no magnitude reduction, unlike conventional low- or high-pass filters. Based on this positive-sequence component, the source phase angle and the reference voltage for compensation have been derived. This method is easier to implement and to tune controller gains. In order to reduce the delay-time effect in the voltage control loop, the reference voltages have been predicted a sampling period ahead. The validity of the compensating performance has been verified by the experimental results for a small prototype active power filter system controlled by a TMS320C31 DSP controller. The negative-sequence component of 10% in the source voltage has been almost suppressed in the load-side voltage and the THD of the source current has been significantly reduced to 3.8% from 44%. The sag of 20% of the source voltage in all three phases as well as in a single phase has been also recovered to the desired balanced set.

## REFERENCES

- [1] J. W. Dixon, J. J. Garcia, and L. A. Moran, "Control system for three-phase active power filter which simultaneously compensates power factor and unbalanced load," *IEEE Trans. Ind. Electron.*, vol. 42, pp. 636–641, Oct. 1995.
- [2] J. Uceda, F. Aldana, and P. Martinez, "Active filters for static power converter," *Proc. Inst. Elect. Eng.*, vol. 130, no. 5, pp. 347–354, 1983.

- [3] W. M. Grady, M. J. Samoty, and A. H. Noyola, "Survey of active line conditioning methodologies," *IEEE Trans. Power Delivery*, vol. 5, pp. 1536–1542, July 1990.
- [4] H. Akagi, "New trends in active filters for power conditioning," *IEEE Trans. Ind. Applicat.*, vol. 3, pp. 1312–1322, Nov./Dec. 1996.
- [5] F. Z. Peng, H. Akagi, and A. Nabae, "A new approach to harmonic compensation in power systems—a combined system of shunt passive and series active filters," *IEEE Trans. Ind. Applicat.*, vol. 26, pp. 983–990, Nov./Dec. 1990.
- [6] A. Campos, G. Joos, P. D. Ziogas, and J. F. Lindsay, "Analysis and design of a series voltage unbalance compensator based on a three-phase VSI operating with unbalanced switching functions," *IEEE Trans. Power Electron.*, vol. 9, pp. 269–274, May 1994.
- [7] M. El-Habrouk, M. K. Darwish, and P. Mehta, "Active power filters: a review," *Proc. IEE—Elect. Power Applicat.*, vol. 147, no. 5, pp. 403–413, 2000.
- [8] L. Moran, I. Pastorini, J. Dixon, and R. Wallace, "Series active power filter compensates current harmonics and voltage unbalance simultaneously," *Proc. IEE—Gen. Transmission Distrib.*, vol. 147, no. 1, pp. 31–36, 2000.
- [9] S. Fukuda and T. Endoh, "Control method for combined active filter system employing a current source converter and a high pass filter," *IEEE Trans. Ind. Applicat.*, vol. 31, pp. 697–703, Sept./Oct. 1995.
- [10] Z. Wang and Q. Wang, "A series active power filter adopting hybrid control approach," *IEEE Trans. Power Electron.*, vol. 16, pp. 301–310, May 2001.
- [11] J. W. Dixon, G. Venegas, and L. A. Moran, "A series active power filter based on a sinusoidal current-controlled voltage source inverter," *IEEE Trans. Ind. Electron.*, vol. 44, pp. 612–620, Oct. 1997.
- [12] S. Srianthumrong, H. Fujita, and H. Akagi, "Stability analysis of a series active filter integrated with a double-series diode rectifier," in *Proc. IEEE PESC*, Galway, Ireland, 2000, pp. 1301–1311.
- [13] J. H. Mark and T. C. Green, "Predictive control of active power filters," in *Proc. IEEE PESC*, 2001, pp. 1396–1401.
- [14] K. Nishida, Y. Konishi, and M. Nakaoka, "Current control implementation with deadbeat algorithm for three-phase current-source active power filter," *Proc. IEE—Elect. Power Applicat.*, vol. 149, no. 4, pp. 275–282, 2002.
- [15] S. J. Lee, J. K. Kang, and S. K. Sul, "A new phase detecting method for power conversion systems considering distorted condition in power system," in *Conf. Rec. IEEE-IAS Annu. Meeting*, 1999, pp. 2167–2172.
- [16] S. G. Jeong and M. H. Woo, "DSP-based active power filter with predictive current control," *IEEE Trans. Ind. Electron.*, vol. 44, pp. 329–336, June 1997.
- [17] S. Bhattacharya, D. Divan, and B. Banerjee, "Synchronous reference frame based harmonic isolator using series active filter," in *Proc. EPE*, vol. 1, Florence, Italy, 1991, pp. 30–35.
- [18] M. Grotzbach and J. Xu, "Noncharacteristic line current harmonic in diode rectifier bridge produced by network asymmetries," in *Proc. EPEP*, Brighton, U.K., 1993, pp. 64–69.



**G.-Myoung Lee** was born in Korea in 1970. He received the B.S. degree from Kyungil University, Kyungbuk, Korea, in 1995, and the M.S. and Ph.D. degrees from Yeungnam University, Kyungbuk, Korea, in 1997 and 2002, respectively, all in electrical engineering.

He was with the Power Electronics Laboratory of Kyongbuk National University under an internship of the Korea Science and Engineering Foundation for one year. Since 2003, he has been with Advanced Drive Technology Company, Ltd., Kyungki-Do, Korea, as a Research Engineer. His current interests include motor drives and static power converters.



**Dong-Choon Lee** (S'90–M'95) received the B.S., M.S., and Ph.D. degrees in electrical engineering from Seoul National University, Seoul, Korea, in 1985, 1987, and 1993, respectively.

He was a Research Engineer with Daewoo Heavy Industry from 1987 to 1988. He also was with the Research Institute of Science Engineering, Seoul National University, under a Post-Doctoral Fellowship for one year. Since 1994, he has been a faculty member of the School of Electrical Engineering and Computer Science, Yeungnam University, Kyongbuk, Korea. As a Visiting Scholar, he was with the Power Quality Laboratory, Texas A&M University, College Station, in 1998, and the Electrical Drive Center, University of Nottingham, Nottingham, U.K., in 2001. His research interests include ac machine drives, control of power converters, active power filters, and wind power generation.

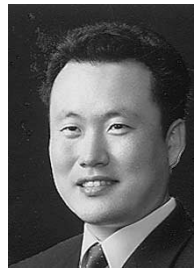

**Jul-Ki Seok** (S'94–M'98) received the B.S., M.S., and Ph.D. degrees in electrical engineering from Seoul National University, Seoul, Korea, in 1992, 1994, and 1998, respectively.

From 1998 to 2001, he was with the Production Engineering Center, Samsung Electronics Company Ltd., Suwon, Korea. In 2001, he joined the School of Electrical Engineering and Computer Science, Yeungnam University, Kyongbuk, Korea, where he is currently an Assistant Professor. His specific research interests are high-performance electrical machine drives and electromagnetic compatibility of electric vehicle drives.